

NDIR GAS ANALYZER

<Replacement for ZRH>

DATA SHEET

ZPA1, H

<This models is a replacement for an obsoleted model ZRH.>

The models ZPA1 and ZPAH are single-beam NDIR gas analyzers which can measure the concentration of up to two component among SO₂, CO₂, CO, and CH₄. ZPA1 is vertical and for wall- or panel-mount, while ZPAH is horizontal and for benchtop or rack-mount.

These are ideal for flue gas measurement in waste incineration plants, boilers, or other industrial furnaces.

FEATURES

1. Easy maintenance

Maintenance is easy due to the simple measurement unit of single-beam system adapted.

2. User-friendly operation

Clear and easy-to-read display of all five gas concentrations at once.

Simple status and maintenance messages.

3. Extensive functions

Various optional functions are available such as auto calibration control, atmospheric pressure correction, high and low concentration alarms, remote range switch, and range identification signal, etc.

SPECIFICATIONS

Standard Specifications

Principle of measurement:

Non-dispersion infrared-ray absorption method
Single light source and single beams (single beam system)

Measurable gas components and measuring range:

	Minimum range	Maximum range
SO ₂	0 - 500ppm	0 - 5000ppm
CO ₂	0 - 500ppm	0 - 100vol%
CO	0 - 500ppm	0 - 100vol%
CH ₄	0 - 1000ppm	0 - 100vol%
CO+CO ₂	0 - 500ppm	0 - 100vol%

- Configurable up to two ranges
 - Measuring range ratio max. 1:10 (1:5 for 2-component analyzer)
- For possible combinations of components and ranges, refer to Table1.

Measured value indication:

- Digital indication in 4 digits (LCD panel with LED back light)
- Instantaneous value of each component



<ZPAH>

<ZPA1>

Analog output signals:

4 to 20 mA DC and 0 to 1 V DC (simultaneous output), max. 4 outputs

* Isolated internally from circuit and ground. Output lines are non-isolated each other.

Allowable load 550Ω for 4 to 20mA DC

Allowable load 100KΩ for 0 to 1V DC

Digital output: (Option)

SPST contact (250V DC/2A, resistive load) max.8 outputs

Instrument error, calibration error, range identification, auto calibration status, solenoid valve drive for auto calibration.

* All relay contacts are isolated mutually and from the internal circuit.

Digital input: (Option)

Voltage contact (supply 5VDC (15mA Max.)) Max. 4 inputs

Remote range change over, auto calibration remote start, remote hold.

* Isolated from the internal circuit with photocoupler.

Power supply:

Voltage rating ; 100V to 240V AC

Allowable range ; 85V to 264V AC

Frequency ; 50Hz/60Hz

Power consumption ; 100VA max.

Operation conditions:

Ambient temperature ;

-5°C to 45°C

Ambient humidity ; 90% RH max., non-condensing

Storage conditions:

Ambient temperature ; -20°C to 60°C

Ambient humidity ; 100% RH max., non-condensing

Dimensions (H x W x D):

133 x 483 x 382mm (ZPAH)

484 x 294 x 170mm (ZPA1)

Mass: Approx. 7 kg max.**Finish color:** Front panel; Cool gray (PANTON 1C-F)**Enclosure:** Steel casing, for indoor use**Material of gas-contacting parts:**

Gas inlet/outlet; SUS304

Sample cell; SUS304, chloroprene rubber

Infrared-ray transmitting window; CaF₂

Internal piping; Toaron, Teflon, Polypropylene

Gas inlet/outlet: Rc1/4 or NPT1/4 internal thread**Purge gas flow rate:** 1L/min (when required)**Standard Functions****Output signal holding:**

Output signals are held unchanged during manual and auto calibrations by activation of holding (turning "ON" its setting).

The values held are those just before start calibration mode or setting value.

Usage is selectable.

Indication of instantaneous values will not be held.

Switch ranges: The switch ranges function is available in manual, auto, and remote modes. Only preset switch method is effective.

Manual: Allows range to switch by key operation.

Auto: Automatically switched from first range to second range when the measured value exceeds 90%FS of first range.

Automatically switched from second range to first range when the measured value drops to 80% or less first range.

Remote: Voltage contact input (Option)

Allows range to switch via an external signal when remote range switch input is received.

When the contact input terminals for each component are input voltage, the first range is selected, and it is switched to the second range when the terminals are open.

* These switch range value are settable between the first range and second range values (low/high range values).

Optional Functions**Remote output holding:**

Output signal is held at the last value or preset value by voltage input to the remote output holding input terminals.

Holding is maintained while the voltage is input to the terminals. Indication of instantaneous values are not held.

Range identification signal:

The present measuring range is identified by a contact position.

The contact output terminals close for each component when the first range is selected, and open when the second range is selected.

Auto calibration:

Auto calibration is carried out periodically at the preset cycle.

When a standard gas cylinder for calibration and a solenoid valve for opening/closing the gas flow line are prepared externally by the customer, calibration will be carried out with the solenoid valve drive contacts for zero calibration and each span calibration turned on/off sequentially at the set auto calibration timing.

Auto calibration cycle setting:

Auto calibration cycle is set.

Setting is variable within 1 to 99 hours (in increments of 1 hour) or 1 to 40 days (in increments of 1 day).

Gas flow time setting:

The time for flowing each calibration gas in auto calibration is set.

Settable within 60 to 900 seconds (in increments of 1 second)

Auto calibration remote start:

Auto calibration starts by opening the auto calibration remote start input terminal after short circuiting for 1.5 sec or longer.

Auto calibration starts when contacts open.

Auto zero calibration:

Auto zero calibration is carried out periodically at the preset cycle.

This cycle is independent from "Auto calibration" cycle.

When zero calibration gas and solenoid valve for opening/closing the calibration gas flow line are prepared externally by the customer, zero calibration will be carried out at the set auto zero calibration timing.

Auto zero calibration cycle setting:

Auto zero calibration cycle is set.

Setting is variable within 1 to 99 hours (in increments of 1 hour) or 1 to 40 days (in increments of 1 day)

Gas flow time setting:

The timing for flowing zero gas in auto zero calibration is set.

Settable within 60 to 900 seconds (in increments of 1 second)

Instrument error contact output:

Contacts turn on at occurrence of analyzer error No. 1, 2, 3 or 10.

Calibration error contact output:

Contacts turn on at occurrence of manual or auto calibration error (any of errors No. 4 to 9).

Auto calibration status contact outputs:

Contacts turn on during auto calibration.

Performance

Repeatability: $\pm 0.5\%$ of full scale
Linearity: 1% of full scale
Zero drift: $\pm 2\%$ of full scale/week
Span drift: $\pm 2\%$ of full scale/week
Response time (for 90% FS response) :
1s to 15 s electrical response. 10 s to 30 s including replacement time of sampling gas.
Gas replacement time depends on the number of measuring components, and measuring range.

Interference from other gases:

Interference component	CO ₂ analyzer	CO analyzer	CH ₄ analyzer	SO ₂ analyzer
CO 1000ppm	$\leq 1.0\%FS$	—	$\leq 1.0\%FS$	$\leq 1.0\%FS$
CO ₂ 15%	—	$\leq 1.0\%FS$ ^{*1)}	$\leq 1.0\%FS$	$\leq 1.0\%FS$
H ₂ O saturation at 20°C	$\leq 1.0\%FS$	$\leq 1.0\%FS$ ^{*1)}	$\leq 1.0\%FS$	—
H ₂ O saturation at 2°C	—	$\leq 2.0\%FS$	—	$\leq 2.0\%FS$
CH ₄ 1000ppm	$\leq 1.0\%FS$	$\leq 1.0\%FS$	—	$\leq 20ppm$

*1) 0-500ppm range or less $\leq 2.0\%FS$

Requirements for Sample Gas

Flow rate: 0.5 \pm 0.2L / min
Temperature: 0 to 50°C
Pressure: 10 kPa or less (Gas outlet side should be open to the atmospheric air.)
Dust: 100 $\mu\text{g}/\text{Nm}^3$ or less in particle size of 0.3 μm or smaller
Mist: Unallowable
Moisture: Less than standard room temperature saturation point.
For SO₂: less than 2°C saturation point
Corrosive component: 1 ppm or less
Standard gas for calibration:
1) Infrared-ray measurable component
Zero gas ; Dry N₂
Span gas ; Each sample gas having concentration 90 to 100% of its measuring range (recommended).

Installation Requirements

- Indoor use (Select a place where the equipment does not receive direct sunlight, draft/rain or radiation from hot substances. If such a place cannot be found, a roof or cover should be prepared for protection.)
- Avoid a place where unit receives heavy vibration
- Select a place where atmospheric air is clean

Principle diagram of NDIR type measurement (For NO, SO₂, CO₂, CO, CH₄)

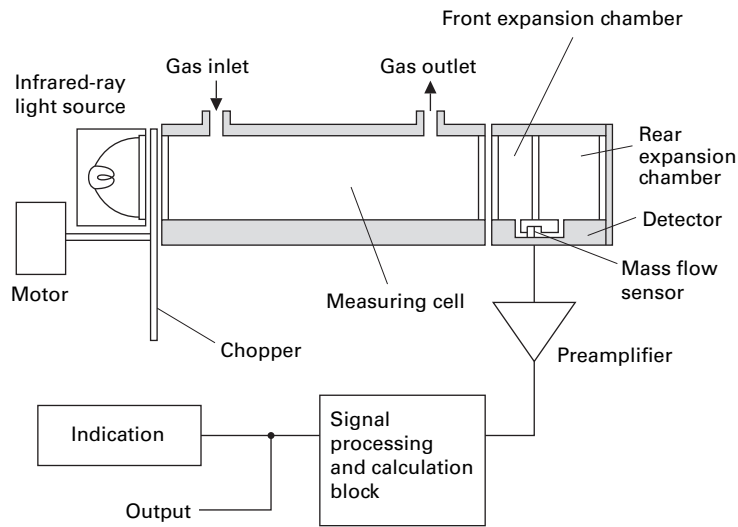

Examples of sampling system configuration including gas analyzer (for reference only)

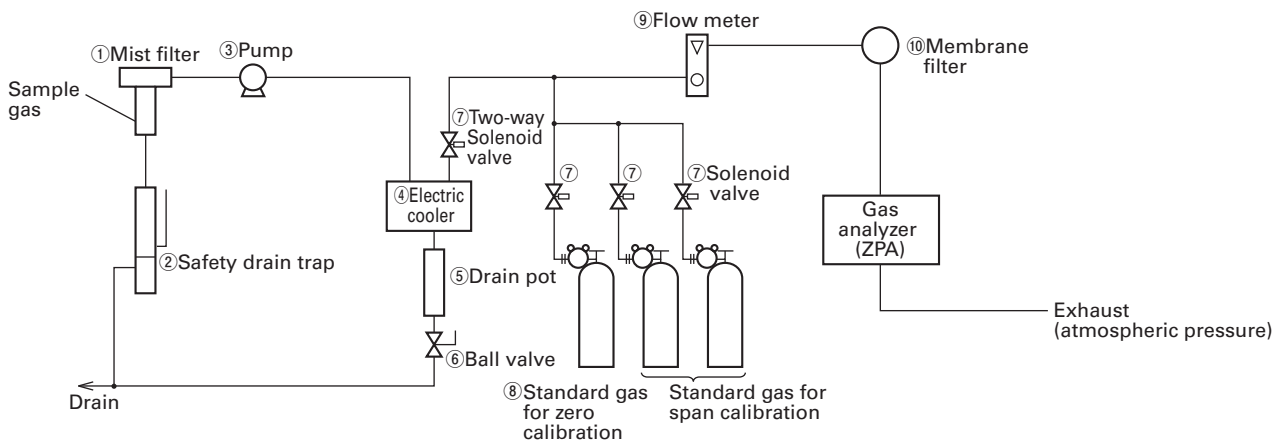

List of sampling devices (example)

No.	Device name	Fuji's type
①	Mist filter	ZBBK1V03-0
②	Safety drain trap	ZBH51603
③	Pump	ZBG80
④	Electric cooler	ZBC91004
⑤	Drain pot	ZBH13003 (Length 255mm)
⑥	Ball valve	ZBFB1
⑦	Two-way solenoid valve	
⑧	Standard gas for calibration	ZBM□Y04-0□ (Codes in □ to be selected depending on application)
⑨	Flow meter	ZBD42203
⑩	Membrane filter	ZBBM2V03-0

Note) The above is a typical configuration example. As configuration may differ depending on measuring objects, please consult us.

CODE SYMBOLS

Digit	Description	Note	1	2	3	4	5	6	7	8	9	10	11	12	13	14	15	16	17	18	19	20	21	22	23	24	25	26
4	<Structure>	<Mounting>	Z	P	A			Y	Z					Y		Y	Y	Y	Y	E			Y	Y				
5	Horizontal (replacement for ZRH1&2) Horizontal (replacement for ZRH1&2) Horizontal (replacement for ZRH1&2) Vertical (replacement for ZRH3&4) Vertical (replacement for ZRH3&4)	Benchtop Rack mount (EIA standard) Rack mount (JIS standard) Panel mount Wall mount						H A H B H C 1 D 1 E																				
6	<Measurable component> 1st component 2nd component							Y A D B E J																				
7	-							Y																				
8	<Revision code>								2																			
9	<Measuring range> 1st component, 1st range	Note 1																										
10	<Measuring range> 1st component, 2nd range	Note 1																										
11	<Measuring range> 2nd component, 1st range	Note 1																										
12	<Measuring range> 2nd component, 2nd range	Note 1																										
13	-																											
14	-																											
15	-																											
16	-																											
17	-																											
18	<Gas connection> Rc1/4 NPT1/4																											
19	<Output> 4-20 mA DC + 0-1 V DC																											
20	<Indication> Japanese English																											
21	-																											
22	<Optional function (DIO)> FAULT Auto calibration Range ID / Remote range switchover																											
23	-																											
24	<Unit> ppm, vol% mg/m ³ , g/m ³	Note 2																										
25	<Adjustment> Standard For heat treatment furnace For converter Others	Note 3																										
26	<Others> Non-standard																											

Note1) Refer to Table 1 for possible combination of measuring components and ranges in this manual. When "Y" is specified at 6th digit, "Y" should be specified at 9th to 16th digit. For fuel cell O₂ analyzer, range is 0-10vol% or more.

Note2) When "B" is specified at 24th digit, measuring range should be specified by ppm range code. In this case NO, SO₂ and CO measuring range are corresponding range in mg/m³. Please refer to the table shown below for the corresponding range code based on "mg/m³".

Note3) When A to D is specified at 25th digit, the analyzer will be adjusted and delivered with the following gasses. Standard "A": balance gas N₂.

For heat treatment furnace "C": balance gas 30vol% H₂/remaining N₂.

For converter "D": balance gas CO, CO₂.

When other adjustment is required, please specify "Z".

When "Z" is specified, please attach a list of gas composition contained in the measuring gas.

Corresponding mg/m³

Range code	Unit : ppm	Corresponding range in mg/m ³	
		SO ₂	CO
E	0-500ppm	0-1,400mg/m ³	0-600mg/m ³
F	0-1,000ppm	0-2,800mg/m ³	0-1,250mg/m ³
G	0-2,000ppm	0-5,600mg/m ³	0-2,500mg/m ³
U	0-2,500ppm	0-7,100mg/m ³	0-3,000mg/m ³
T	0-3,000ppm	0-8,500mg/m ³	0-3,750mg/m ³
H	0-5,000ppm	0-14.00g/m ³	0-6,250mg/m ³

The conversion formula "ppm" unit into "mg/m³" unit.

SO₂ (mg/m³) = 2.86 × SO₂ (ppm)

CO (mg/m³) = 1.25 × CO (ppm)

Range code

Range	Code	Range	Code
None	Y	0~1vol%	J
0~500ppm	E	0~2vol%	K
0~1000ppm	F	0~3vol%	Q
0~2000ppm	G	0~5vol%	L
0~2500ppm	U	0~10vol%	M
0~3000ppm	T	0~20vol%	N
0~5000ppm	H	0~25vol%	V
		0~40vol%	W
		0~50vol%	P
		0~70vol%	X
		0~100vol%	R
		Others	Z

Table 1 Measurable component and range - availability check table -

Procedure of range selection

On one component analyzer:

First determine 1st range, then select 2nd range from the corresponding right column.

More than two components analyzer:

The 2nd range in the tables for two and more components is maximum available range.

Select the 2nd range less than or equal to the "2nd range (max)".

1-component analyzer : CO

1st range	2nd range
0 - 500ppm	None, 0 - 1000ppm,2000ppm,2500ppm,3000ppm,5000ppm
0 - 1000ppm	None, 0 - 2000ppm,2500ppm,3000ppm,5000ppm,1%
0 - 2000ppm	None, 0 - 2500ppm,3000ppm,5000ppm,1%,2%
0 - 2500ppm	None, 0 - 3000ppm,5000ppm,1%,2%
0 - 3000ppm	None, 0 - 5000ppm,1%,2%
0 - 5000ppm	None, 0 - 1%,2%,3%,5%
0 - 1%	None, 0 - 2%,3%,5%,10%
0 - 2%	None, 0 - 3%,5%,10%,20%
0 - 3%	None, 0 - 5%,10%,20%,25%
0 - 5%	None, 0 - 10%,20%,25%,40%,50%
0 - 10%	None, 0 - 20%,25%,40%,50%,70%,100%
0 - 20%	None, 0 - 25%,40%,50%,70%,100%
0 - 25%	None, 0 - 40%,50%,70%,100%
0 - 40%	None, 0 - 50%,70%,100%
0 - 50%	None, 0 - 70%,100%
0 - 70%	None, 0 - 100%
0 - 100%	None

1-component analyzer : CO₂

1st range	2nd range
0 - 500ppm	None, 0 - 1000ppm,2000ppm,2500ppm,3000ppm,5000ppm
0 - 1000ppm	None, 0 - 2000ppm,2500ppm,3000ppm,5000ppm,1%
0 - 2000ppm	None, 0 - 2500ppm,3000ppm,5000ppm,1%,2%
0 - 2500ppm	None, 0 - 3000ppm,5000ppm,1%,2%
0 - 3000ppm	None, 0 - 5000ppm,1%,2%
0 - 5000ppm	None, 0 - 1%,2%,3%,5%
0 - 1%	None, 0 - 2%,3%,5%,10%
0 - 2%	None, 0 - 3%,5%,10%,20%
0 - 3%	None, 0 - 5%,10%,20%,25%
0 - 5%	None, 0 - 10%,20%,25%,40%,50%
0 - 10%	None, 0 - 20%,25%,40%,50%,70%,100%
0 - 20%	None, 0 - 25%,40%,50%,70%,100%
0 - 25%	None, 0 - 40%,50%,70%,100%
0 - 40%	None, 0 - 50%,70%,100%
0 - 50%	None, 0 - 70%,100%
0 - 70%	None, 0 - 100%
0 - 100%	None

1-component analyzer : SO₂

1st range	2nd range
0 - 500ppm	None, 0 - 1000ppm,2000ppm,2500ppm,3000ppm,5000ppm
0 - 1000ppm	None, 0 - 2000ppm,2500ppm,3000ppm,5000ppm,1%
0 - 2000ppm	None, 0 - 2500ppm,3000ppm,5000ppm,1%,2%
0 - 2500ppm	None, 0 - 3000ppm,5000ppm,1%,2%
0 - 3000ppm	None, 0 - 5000ppm,1%,2%
0 - 5000ppm	None, 0 - 1%,2%,3%,5%
0 - 1%	None, 0 - 2%,3%,5%,10%
0 - 2%	None, 0 - 3%,5%,10%
0 - 3%	None, 0 - 10%
0 - 5%	None, 0 - 10%
0 - 10%	None

1-component analyzer : CH₄

1st range	2nd range
0 - 1000ppm	None, 0 - 2000ppm,2500ppm,3000ppm,5000ppm,1%
0 - 2000ppm	None, 0 - 2500ppm,3000ppm,5000ppm,1%,2%
0 - 2500ppm	None, 0 - 3000ppm,5000ppm,1%,2%
0 - 3000ppm	None, 0 - 5000ppm,1%,2%
0 - 5000ppm	None, 0 - 1%,2%,3%,5%
0 - 1%	None, 0 - 2%,3%,5%,10%
0 - 2%	None, 0 - 3%,5%,10%,20%
0 - 3%	None, 0 - 5%,10%,20%,25%
0 - 5%	None, 0 - 10%,20%,25%,40%,50%
0 - 10%	None, 0 - 20%,25%,40%,50%,70%,100%
0 - 20%	None, 0 - 25%,40%,50%,70%,100%
0 - 25%	None, 0 - 40%,50%,70%,100%
0 - 40%	None, 0 - 50%,70%,100%
0 - 50%	None, 0 - 70%,100%
0 - 70%	None, 0 - 100%
0 - 100%	None

OUTLINE DIAGRAMS (Unit : mm)

ZPAH (horizontal type)

<TOP VIEW>

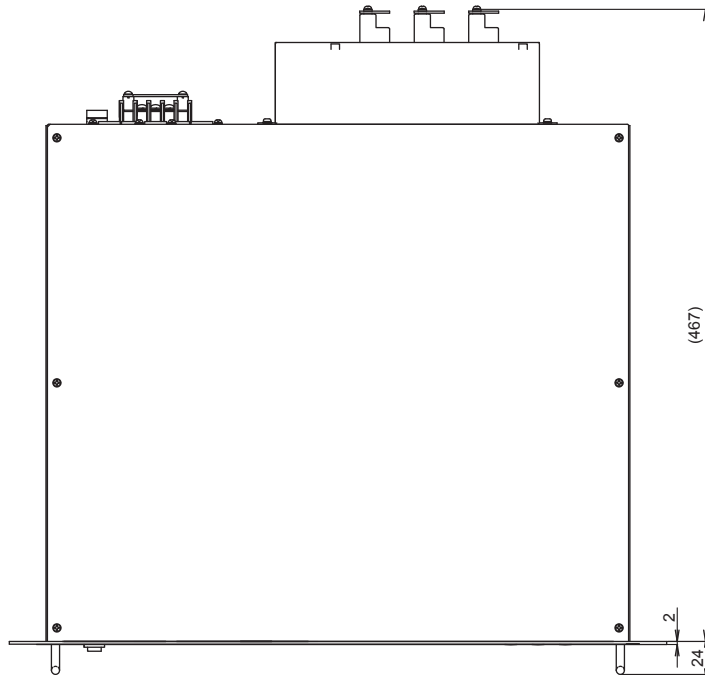

<FRONT VIEW>

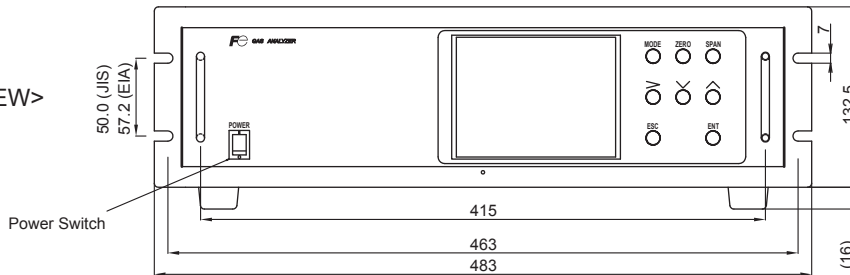

<REAR VIEW>

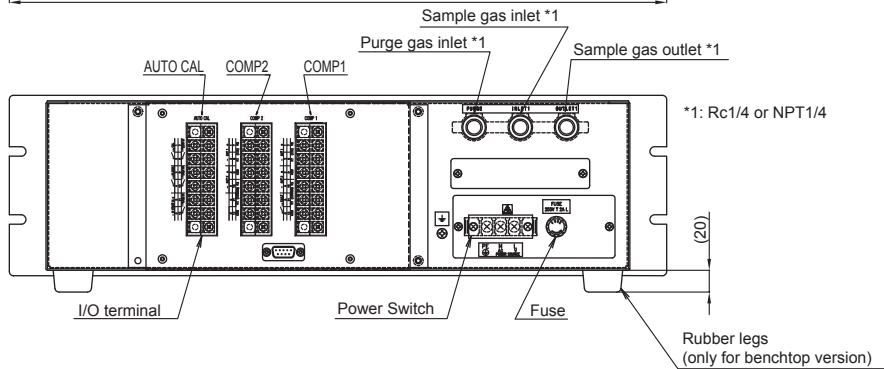

Mounting method

The analyzer weight should be supported at the bottom of the case.

19-inch rack mounting type

<Rack dimensions>

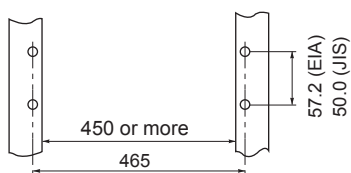

Mounting diagram

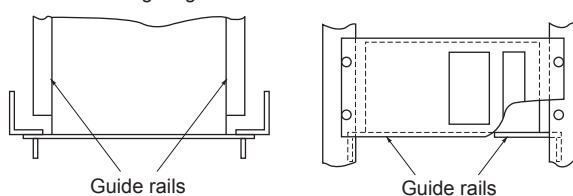

ZPA1E (vertical type, wall mount)

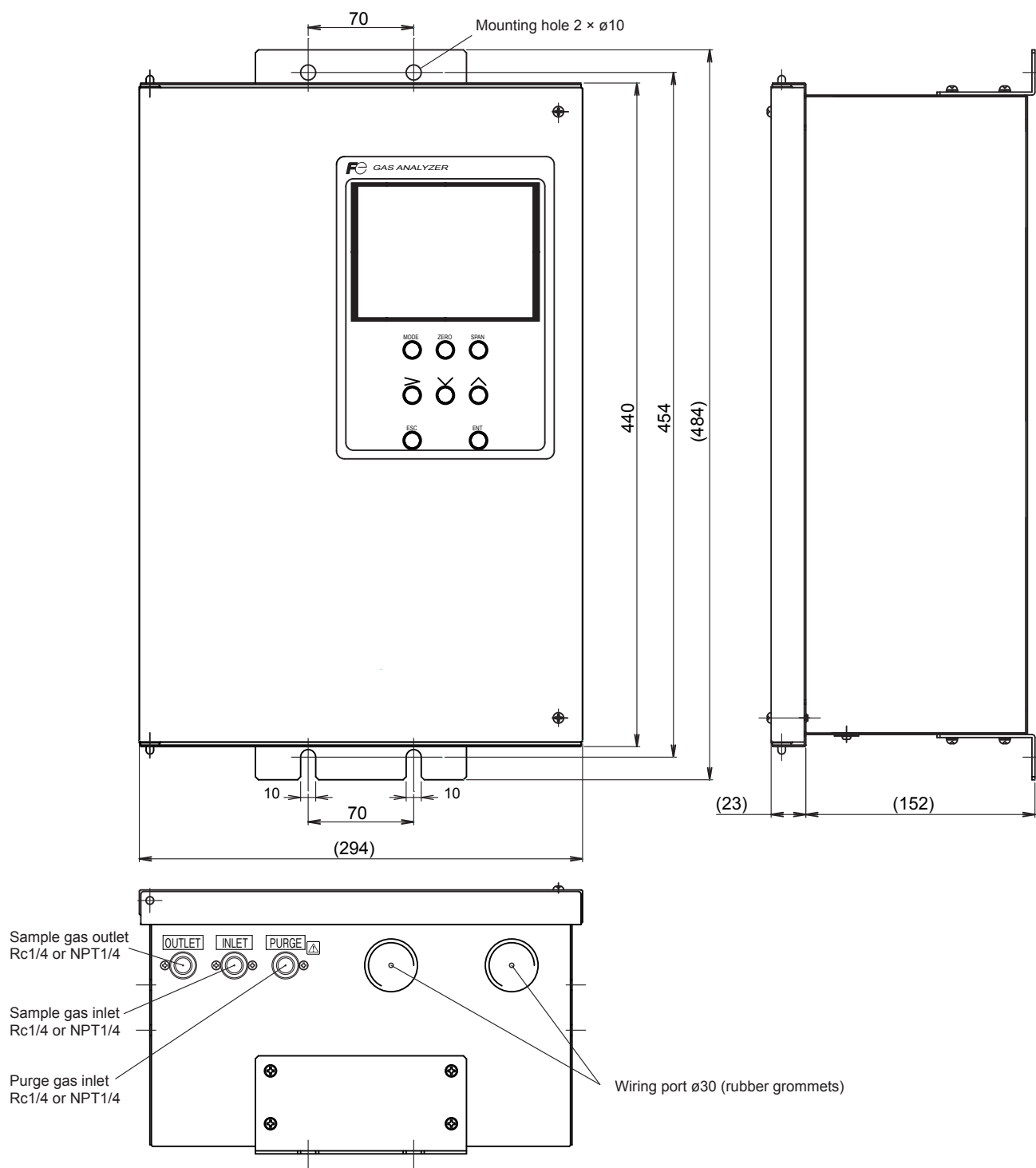

ZPA1D (vertical type, panel mount)

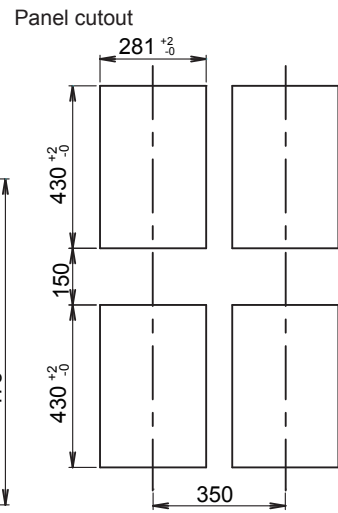
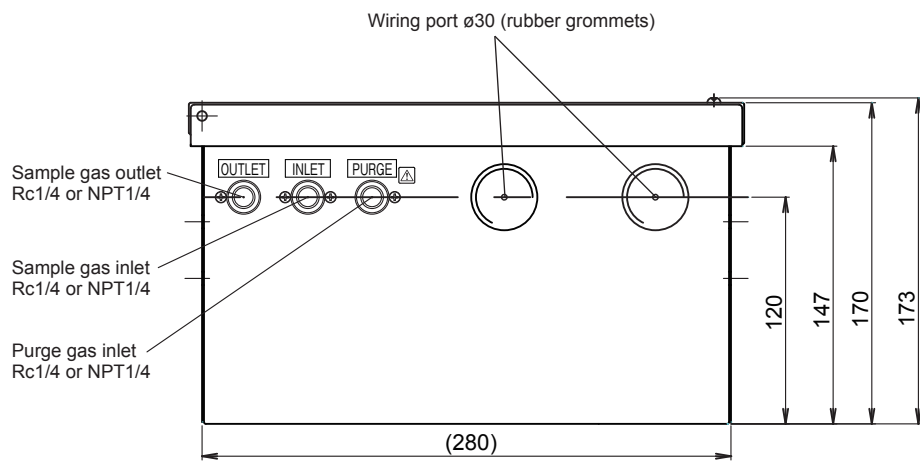
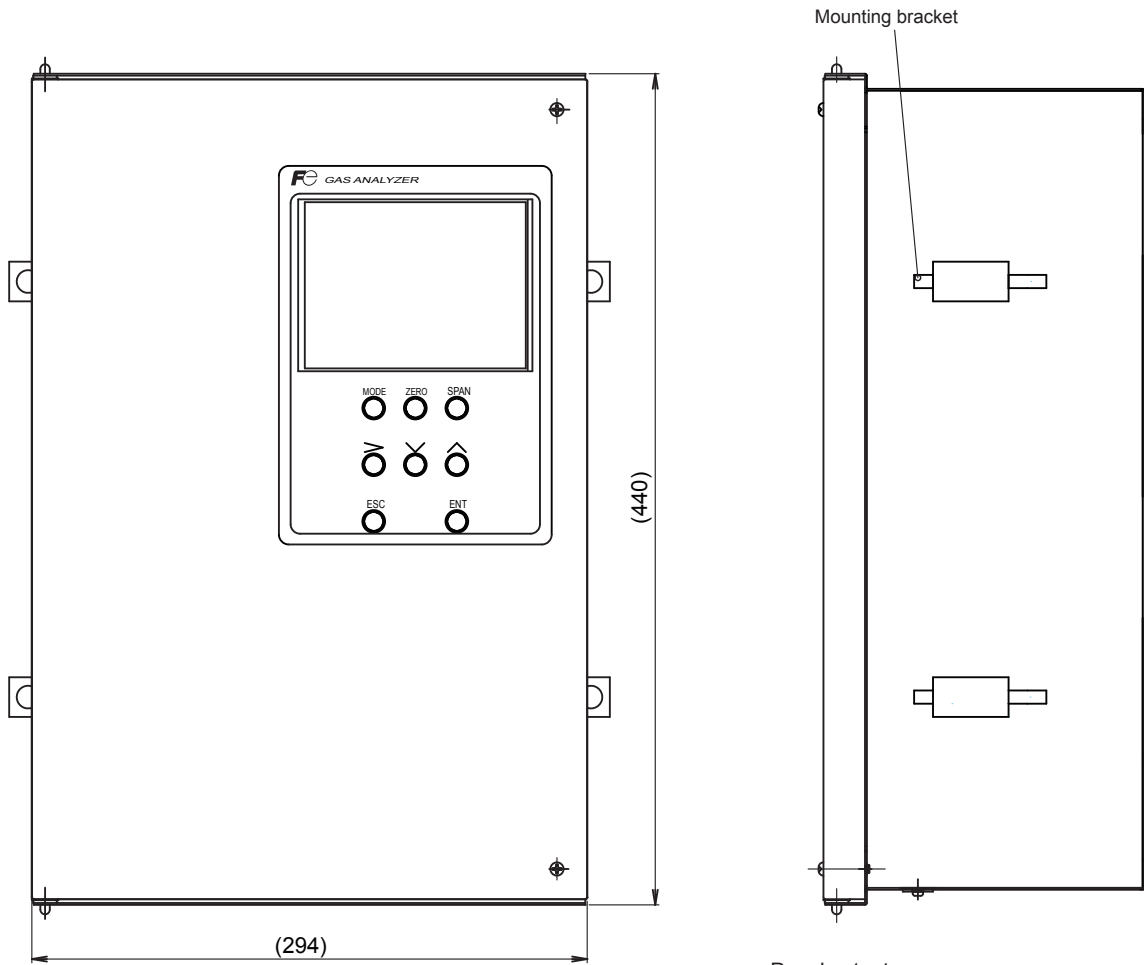

EXTERNAL CONNECTION

Power terminal

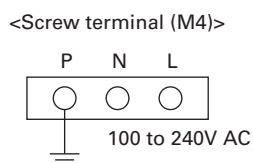

SCOPE OF DELIVERY

- Gas analyzer ... 1 unit
- Replacement fuse (250V AC, 2A, delay type) ... 2 pcs
- Instruction manual ... 1 copy
- Ferrite core ... 4 pcs
- Mounting bracket (when panel-mount version is selected) ... 1 set

ORDERING INFORMATION

1. Code symbols
2. Application and composition of sample gas

I/O terminal for the 1st component (COMP1)

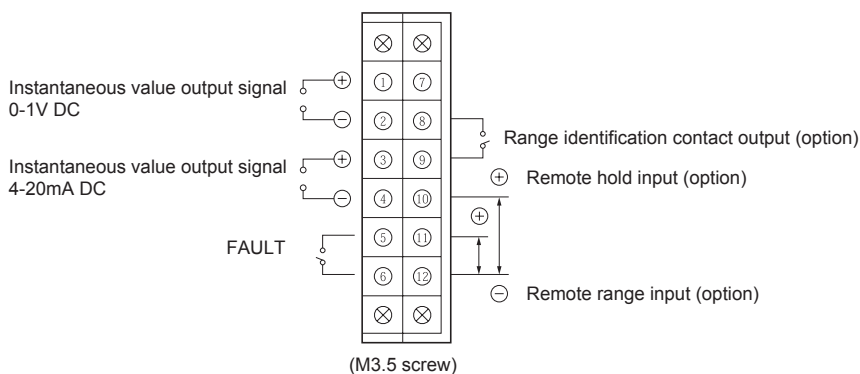

I/O terminal for the 2nd component (COMP2)

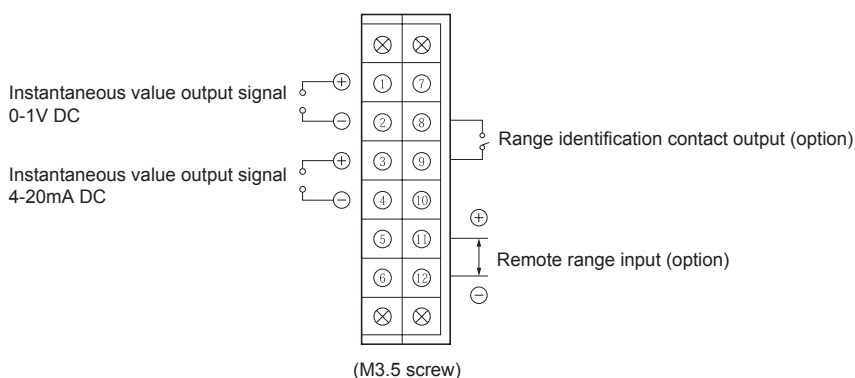

I/O terminal for auto calibration (AUTO CAL)

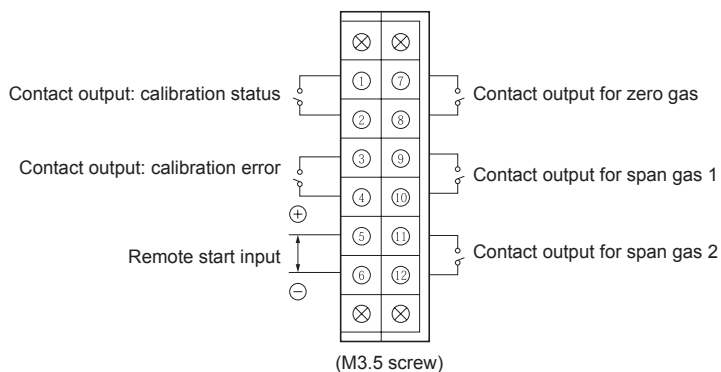

⚠ Caution on Safety

*Before using this product, be sure to read its instruction manual.

 Fuji Electric Co., Ltd.

Instrumentation & Sensors Planning Dept.
1, Fuji-machi, Hino-city, Tokyo 191-8502, Japan
<http://www.fujielectric.com>
Phone: +81-42-514-8930 Fax: +81-42-583-8275
<http://www.fujielectric.com/products/instruments/>