

Simultaneous Measurement of 5 Components in Flue Gas
NO_x, SO₂, CO, CO₂ and O₂ ANALYZER
(for N₂O, CH₄ also optionally) **Type ZSU-5**

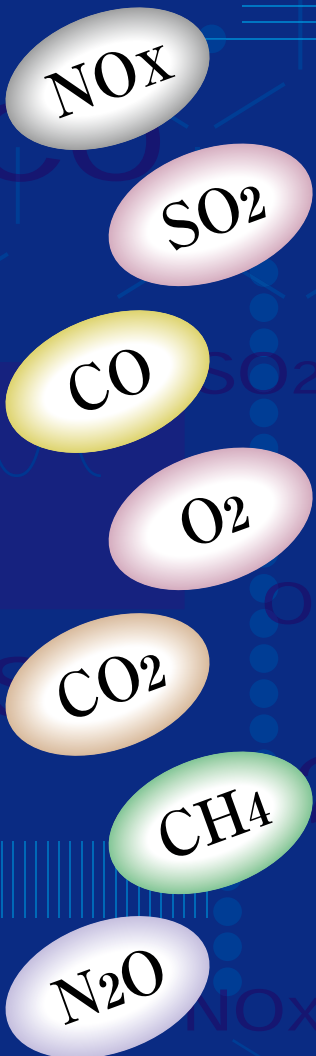

A single instrument measures concentrations of 5 different gases accurately, simultaneously and continuously!

- **Simultaneously and continuously measures concentrations of 5 different gases of NO_x, SO₂, CO, CO₂, O₂ (and, optionally, N₂O and CH₄).**
- **Adopts a double beam infrared analyzer, a Zirconia type oxygen meter or magnetic oxygen meter with high sensitivity and excellent long-term stability.**
- **The maintenance type on the front saves space.**
- **The correction resorting to a twin detector ensures the measurement is free from the majority of interference caused by other gases.**
- **The back-lit LCD indicates changes in 5 components simultaneously in real time.**

Continuously measures and monitors concentrations of flue gases generated from boilers or garbage incinerators

CO and O₂ measurement complies with the Japanese regulation on dioxin emission, while N₂O and CH₄ can also be optionally measured.

Analog output of readings for 5 components

Instantaneous values: NO_x, SO₂, CO, CO₂, O₂
 O₂ corrected instantaneous values: NO_x, SO₂, CO
 O₂ corrected average values: NO_x, SO₂, CO
 O₂ average values: O₂

Easy-to-see back-lit LCD indication

Represents change of concentrations of 5 components simultaneously in real time.

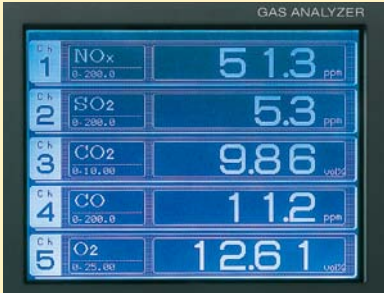

Measurement gas inlet

Easily replaceable filter

Sampling of gases while eliminating moisture and foreign matter

Houses six 3.4 L standard gas cylinders

Can accommodate up to 6 zero and span standard gas cylinders.

Space-saving design

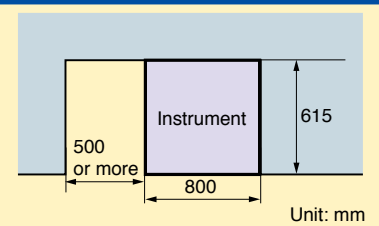

Menu screen

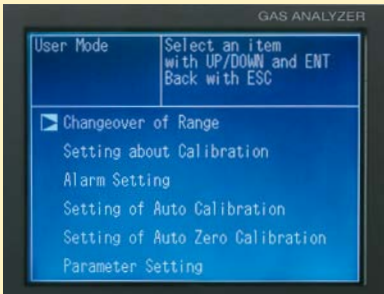

Setting screen

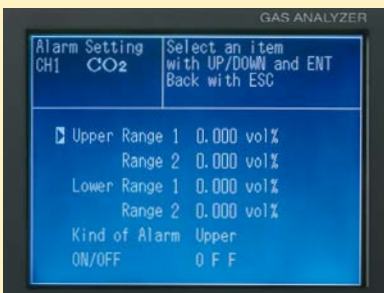

Zirconia oxygen meter that continuously measures the oxygen concentrations (0 to 25%) in sample gases

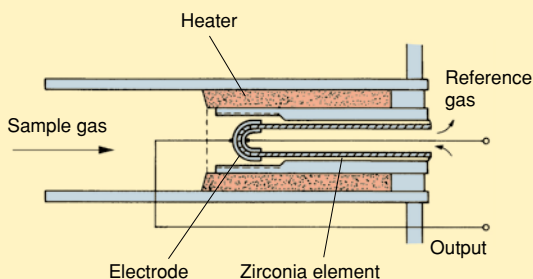

Detects the EMF (electromotive force) of an oxygen concentration cell generated on electrodes on the front and rear of the Zirconia element

High-response magnetic oxygen meter dispensing with auxiliary gas and unaffected by combustible gases

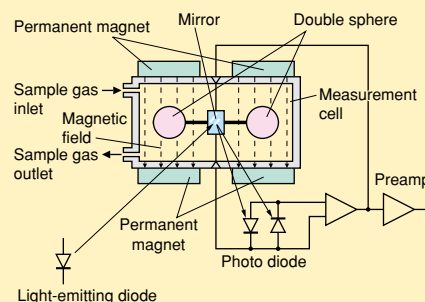

When sample gas enters the measurement cell, the oxygen molecule is attracted to a field where there is considerable magnetic field strength, so that a force corresponding to the oxygen concentration is applied to the double sphere, where it is then converted into an electrical signal.

Gas analyzer realized by the concentration of long-term accumulated know-how

Applicable to garbage and industrial refuse incinerators, gas boilers, sludge burning and oil/coal boilers, iron and steel heating furnaces, etc.

Measures NO_x, SO₂, CO and CO₂ concentrations via an infrared method

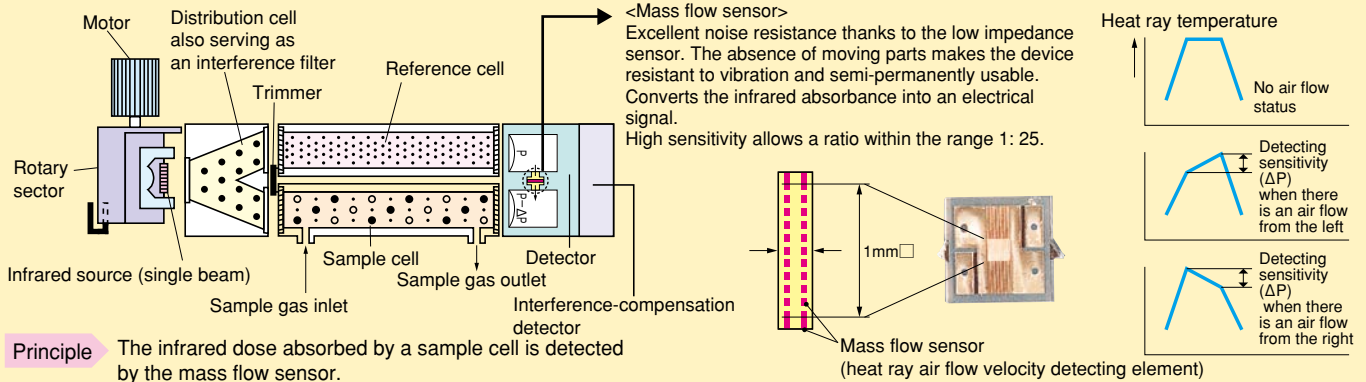

A paper-less recorder can be housed (option)



Type: PHR

Number of recording points: 9 or 18
Indicator: Color LCD
Recording medium: Compact flash memory (2 GB max.)
Input signal: 4 to 20 mA DC,
1 to 5 V DC,
thermocouple,
resistance bulb, etc.

Gas extractor with easily replaceable filter

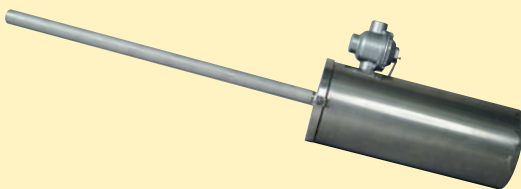

Sampling point temperature	Sampling tube material
Max. 800°C	SUS316
Max. 1000°C	Titanium
Max. 1300°C	SiC

SUS316 wire mesh filter provided.
Power supply 100 V AC, 100 VA.

Japanese pattern approval

- No. SAS992-1 (SO₂ meter)
- No. SAC992-1 (CO meter)
- No. SAN991-1 (NO_x meter)
- No. SE981
(Zirconia O₂ meter)
- No. SF011
(Magnetic O₂ meter)

Gas sampling system

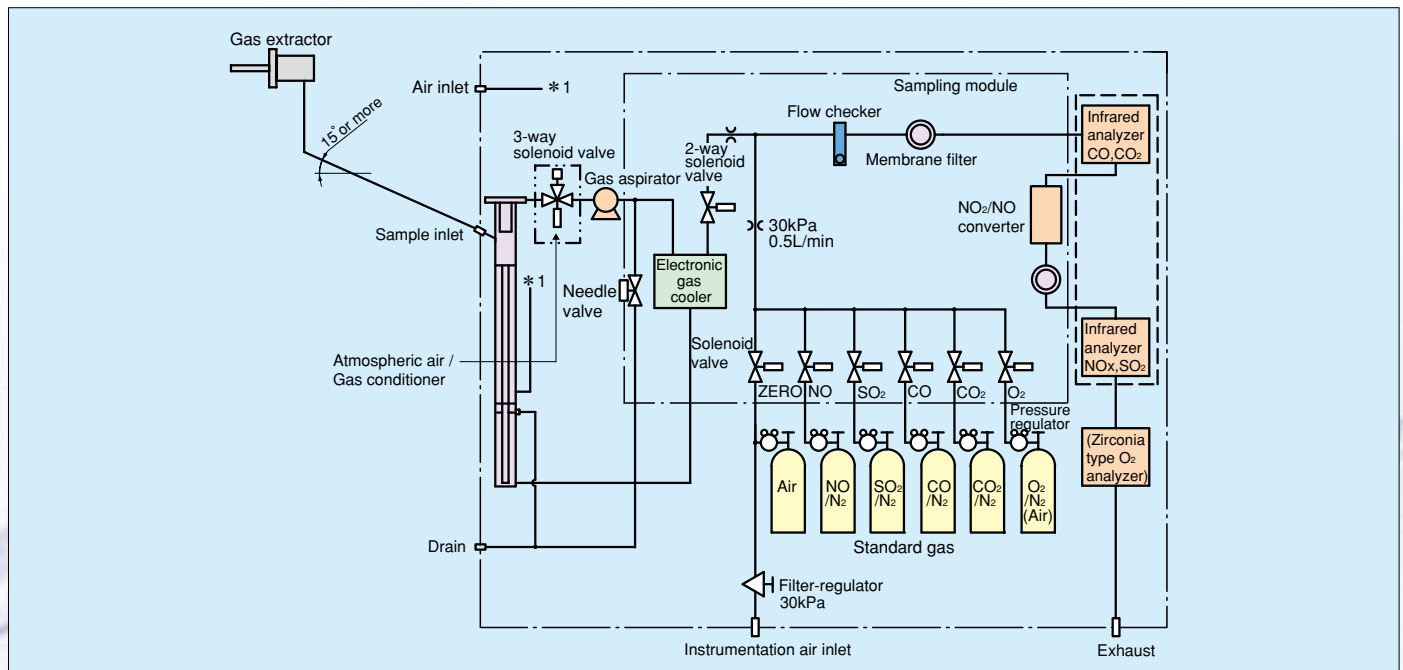

Code symbols

ZSU 4 5 6 7 8 9 10 11 12 13 14 15 16 17 18 19 20 21 22 23 24 25 26 27 28 29 30

Digit	Description	Code
4	<Measuring component>	
	NOx	P
	SO ₂	A
	CO	B
	NO _x ,SO ₂	F
	NO _x ,CO	H
	NO _x ,SO ₂ ,CO	L
NO _x ,SO ₂ ,CO,CO ₂	M	
5	<O₂ meter, O₂ correction value>	
	Without	0
	Zirconia type 4%(Oil fuel)	4
	Zirconia type 5%(Gas fuel)	5
	Zirconia type 6%(Coal fuel)	6
	Zirconia type 12%(Refuse incinerator)	C
	Magnetic type 4%(Oil fuel)	D
	Magnetic type 5%(Gas fuel)	E
Magnetic type 6%(Coal fuel)	F	
Magnetic type 12%(Refuse incinerator)	G	
6	<NO_x measurement range>	
7	See Table 1	
8	<Improved NO>	5
9	<SO₂ measurement range>	
10	See Table 1	
11	<CO measurement range>	
12	See Table 1	
13	<O₂ measurement range>	
	Without	0
	25%	2
10/25%	1	
14	<CO measurement range>	
	Without	YY
	10/20%	MN
	10/ Without	MY
20/ Without	NY	
16	<Analog instantaneous value isolated output>(Note 1)	
	Without	Y
	NO _x (Isolated)	A
	SO ₂ (Isolated)	B
	CO (Isolated)	C
	NO _x ,SO ₂ (Isolated)	D
	NO _x ,CO (Isolated)	E
	NO _x ,SO ₂ ,CO (Isolated)	F
	NO _x ,SO ₂ ,CO,CO ₂ (Isolated)	G
	NO _x ,O ₂ (Isolated)	H
	SO ₂ ,O ₂ (Isolated)	J
	CO,O ₂ (Isolated)	K
	NO _x ,SO ₂ ,O ₂ (Isolated)	L
	NO _x ,CO,O ₂ (Isolated)	M
NO _x ,SO ₂ ,CO,O ₂ (Isolated)	N	
NO _x ,SO ₂ ,CO,CO ₂ ,O ₂ (Isolated)	P	
17	<O₂ correction value isolated output>(Note 1)	
	Without	0
	NO _x (Isolated)	1
	SO ₂ (Isolated)	2
	CO (Isolated)	3
	NO _x ,SO ₂ (Isolated)	4
	NO _x ,CO (Isolated)	5
	SO ₂ ,CO (Isolated)	6
NO _x ,SO ₂ ,CO (Isolated)	7	
18	<O₂ correction value average isolated output>(Note 1)	
	Without	0
	NO _x (Isolated)	1
	SO ₂ (Isolated)	2
	CO (Isolated)	3
	NO _x ,SO ₂ (Isolated)	4
	NO _x ,CO (Isolated)	5
	SO ₂ ,CO (Isolated)	6
NO _x ,SO ₂ ,CO (Isolated)	7	
19	Sample gas pressure / External moisture separator	
	-1~+5kPa Without	1
	-3~+3kPa Without	2
	-5~+1kPa Without	3
	-1~+5kPa With (Note 3)	4
	-3~+3kPa With (Note 3)	5
	-5~+1kPa With (Note 3)	6

Digit	Description	Code
20	<Locker structure>	
	Indoor	1
	Outdoor	2
	(Piping port) (Wiring port) (Piping port if provided with gas cylinder outside)	
21	Upper left / Upper left / Without	A
	Upper left / Upper left / Lower left 3	C
	Upper left / Upper left / Lower left 6	D
22	<Ambient temperature>	
	-5~40°C	2
	-10~40°C	3
23	<Tag plate> <Language>	
	Without Japanese	A
	With Japanese	B
	Without English	E
	With English	F
24	<Recorder> (Note 4)	
	Without	0
	With (6-point recorder: Recording contents 1)	1
	With (6-point recorder: Recording contents 2)	2
	With (6-point recorder: Recording contents 3)	3
	With (6-point recorder: Recording contents 4)	4
	With (6-point recorder: Recording contents 5)	5
	With (6-point recorder: Recording contents 6)	6
With (Others)	Z	
25	<Power supply>	
	100V AC 50Hz	A
	100V AC 60Hz	B
	110V AC 50Hz	C
	110V AC 60Hz	D
	115V AC 50Hz	E
	115V AC 60Hz	F
	200V AC 50Hz	G
200V AC 60Hz	H	
230V AC 50Hz	J	
230V AC 60Hz	K	
26	<Use>	
	Garbage/industrial refuse	A
	Gas boiler	B
	Sludge burning	C
	Oil/coal boiler	D
27	<Measure Act Examination>	
	Without	Y
	NO _x	A
	SO ₂	B
	CO	C
	NO _x , SO ₂	D
	NO _x , CO	E
	NO _x , SO ₂ , CO	F
NO _x , O ₂	G	
SO ₂ , O ₂	H	
CO, O ₂	J	
NO _x , SO ₂ , O ₂	K	
NO _x , CO, O ₂	L	
NO _x , SO ₂ , CO, O ₂	M	
28	<Zero gas> (Note 2)	
	Without Instrumentation air	1
	Atmospheric air	2
	Standard gas provided (Separately specify type ZSY)	3
29	<Sampler> <Sampling tube material> <Insertion length> <Sampling point temperature>	
	Without Without Without -	Y
	With Without Without -	1
	With SUS316 300mm 800°C below	A
	With SUS316 400mm 800°C below	B
	With SUS316 600mm 800°C below	C
	With SUS316 800mm 800°C below	E
	With SUS316 1000mm 800°C below	G
	With SUS316 1200mm 800°C below	H
	With SUS316 1500mm 800°C below	J
	With SUS316 2000mm 800°C below	K
	With Titanium 600mm 1000°C below	P
	With Titanium 800mm 1000°C below	Q
	With Titanium 1000mm 1000°C below	R
With SIC 700mm 1300°C below	D	
With SIC 900mm 1300°C below	F	

Digit	Description	Code
30	<Sample inlet tube kind> <Length>	
	to be arranged by user	Y
	φ 10/8 Teflon tube 5m	A
	φ 10/8 Teflon tube 10m	B
	φ 10/8 Teflon tube 15m	C
	φ 10/8 Teflon tube 20m	D
	φ 10/8 Teflon tube 25m	E
	φ 10/8 Teflon tube 30m	F
	φ 10/8 Teflon tube 50m	G
	Heating tube 10m	H
	Heating tube 15m	J
	Heating tube 20m	K
	Heating tube 25m	L
	Heating tubes 30m	M

<Table 1>Measurement range and code

Measurement range	Code
Without	YY
50/100ppm	AB
50/200ppm	AC
50/250ppm	AD
50/500ppm	AE
50/1000ppm	AF
50/Without	AY
100/200ppm	BC
100/250ppm	BD
100/500ppm	BE
100/1000ppm	BF
100/2000ppm	BG
100/Without	BY
200/500ppm	CE
200/1000ppm	CF
200/2000ppm	CG
200/5000ppm	CH
200/Without	CY
250/500ppm	DE
250/1000ppm	DF
250/2000ppm	DG
250/5000ppm	DH
250/Without	DY
500/1000ppm	EF
500/2000ppm	EG
500/5000ppm	EH
500/Without	EY
1000/2000ppm	FG
1000/5000ppm	FH
1000/Without	FY
2000/5000ppm	GH
2000/Without	GY
5000/Without	HY

Note 1. The output is non-isolated only when "Without" is selected in all of the 16th to 18th digits. Isolated and non-isolated outputs cannot be combined.

Note 2. Specify code 3 for the Measure Act and/or CO₂ meter. Separately specify for standard gas (Type ZSY).

Note 3. Specify the external moisture separator and drain pot when the downward inclination of the sample inlet tube from the gas extraction point to the analyzer gas inlet is less than 15 ° or when the moisture content of the sample gas exceeds 30%.

Note 4. The delivered recorder (Type PHR) is wired so that its recording contents will be as follows. For figures other than those specified in the table below, specify expressly.

Recording contents	Code 1	Code 2	Code 3	Code 4	Code 5	Code 6
NO _x instantaneous value			○			○
Average value	○	○	○			○
O ₂ correction value			○			○
SO ₂ instantaneous value			○		○	
Average value	○		○		○	
O ₂ correction value			○		○	
CO instantaneous value		○		○		
Average value	○	○		○		
O ₂ correction value			○			
O ₂ instantaneous value	○	○	○	○	○	○
Burning temperature	○	○		○		
Dust collection chamber temperature	○	○		○		

Main specifications

Measuring principle	NO _x , SO ₂ , CO, CO ₂ : Non-dispersion infrared (NDIR) O ₂ : Zirconia or magnetic force
Measuring component measurement range	NO _x : 0~50ppm.....5000ppm SO ₂ : 0~50ppm.....5000ppm CO : 0~50ppm.....5000ppm CO ₂ : 0~10% / 0~20% O ₂ : 0~10% / 0~25% (2 ranges each, maximum range ratio 1: 25 except O ₂) * Optionally, N ₂ O and CH ₄ can be measured
Repeatability	±0.5% FS
Linearity	±1.0% FS max
Zero drift	±1.0% FS max./week(±2.0% FS/week max. if range is less than 200ppm) ±2.0% FS max./month for O ₂ meter
Span drift	±2.0% FS max./week ±2.0% FS max./month for O ₂ meter
Measurement gas extractor	About 2L/min
Response speed	120 seconds max. for 90% response from the analyzer inlet (240 seconds max./month for the SO ₂ meter)
Output signal	4 to 20mA DC Instantaneous value output (each measurement gas component concentration) O ₂ correction instantaneous value output O ₂ correction average value output Allowable load resistance: 550 Ω max. (750 Ω max. for isolated output)
External contact input	No-voltage contact Automatic calibration start, average value reset, range changeover, output hold, pump OFF
Contact output	Each component range identification, analyzing section error, calibration error, auto calibration status, maintenance status, CO peak count alarm, each component instantaneous concentration alarm, analyzing section power OFF

Auto calibration function	Zero, span are auto calibrated (calibration cycle settable)
Indication	Back-lit LCD Each component instantaneous value, O ₂ correction instantaneous value, O ₂ correction average value, O ₂ average value Parameter setting (In Japanese or English as specified)
Locker inside fluorescent lamp	Standard provided
Recorder (option)	Paper-less recorder (Type PHR) can be housed
Gas extractor	Electric heating type (40 μm SUS316 wire mesh filter provided) Flange: JIS5K 65A Power supply: 100V AC 50/60Hz Sampling tube material: SUS316 or titanium, SiC
Sample inlet tube	φ 10/ φ 8mm Teflon tube or heating tube (30m max.) Specify the heating tube in the following cases • Ambient temperature is lower than -5°C • SO ₂ range is 100ppm or lower • For SO ₂ measurement, the heating tube length is 10 m or more
Dimensions	Indoor type: 1710(H)×800(W)×615(D)mm Outdoor type: 1780(H)×815(W)×700(D)mm
Mass	About 300kg (standard gas excluded)
Ambient conditions	-5 to +40°C or -10 to +40°C, 90% RH max
Source voltage	100, 110, 200, 230V AC 50 or 60Hz as specified
Power consumption	600VA max. (gas extractor, heating tube excluded)
Measurement gas conditions	Temperature: 60 to 800°C (standard) Non-standard: 1000°C (Gas extractor tube material: Titanium) 1300°C (Gas extractor tube material: SiC) Dust: 100mg/Nm ³ max., Pressure: -3~+3kPa Component: SO ₂ 500ppm max., NO _x 1000ppm max. CO ₂ 0~15%, CO 0~2000ppm, O ₂ 1~21%, HCl 100ppm max.

Dimensions (Unit: mm)

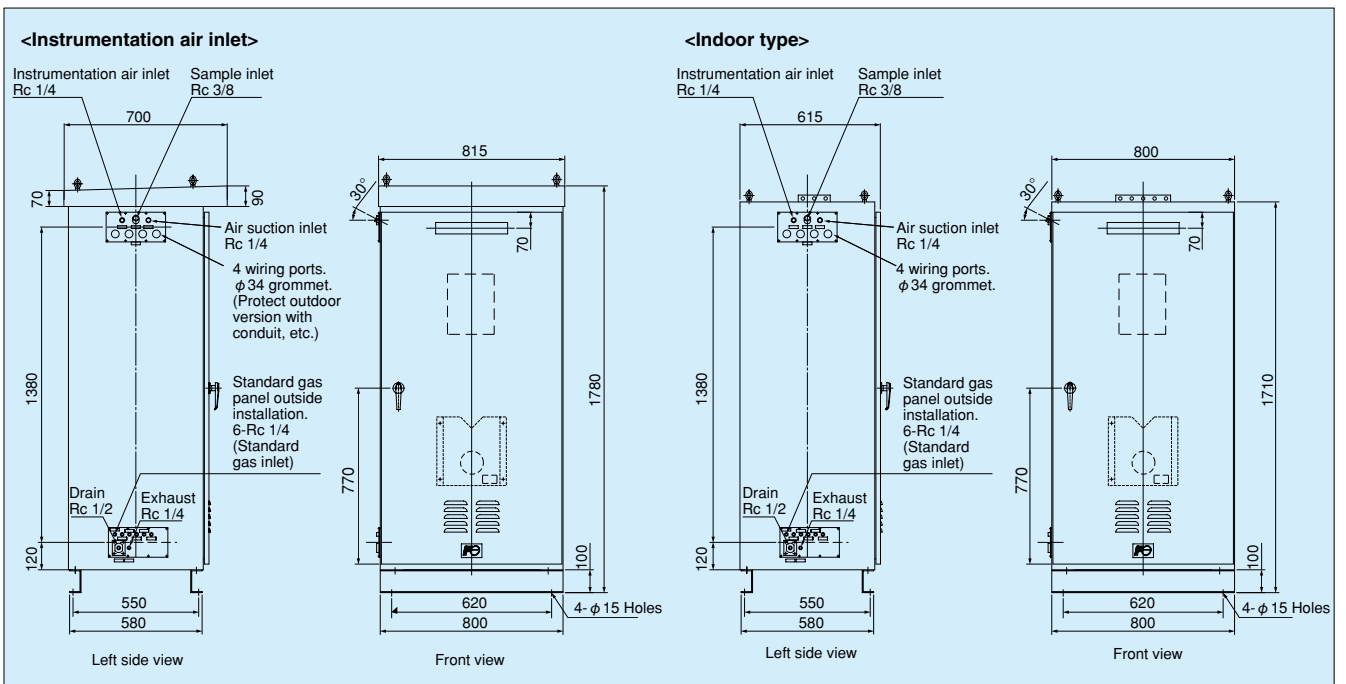

Electric heating gas extractor

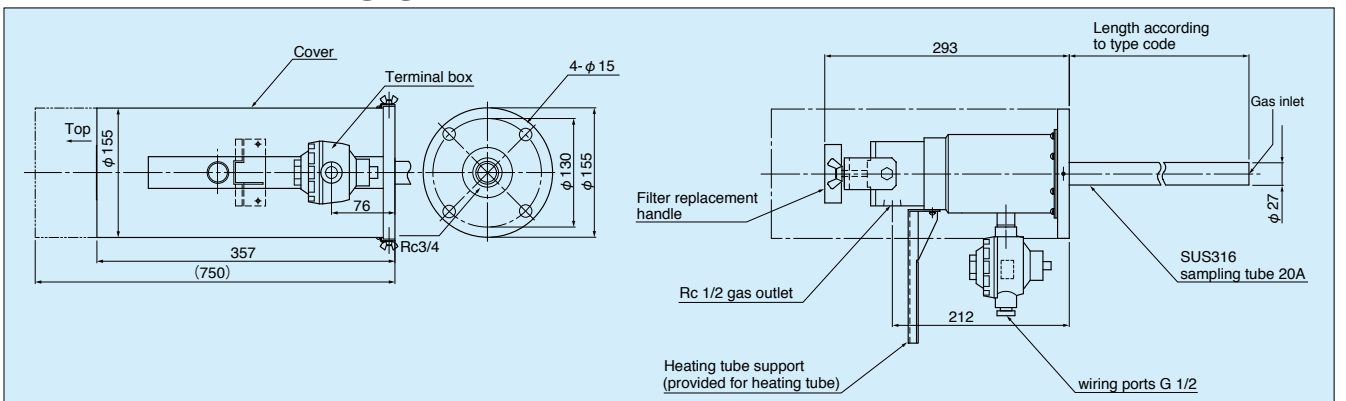

Related products

To prevent dioxin emissions from the incinerator

CO, O₂ analyzer <Type ZSQ>



Japanese pattern approval

SAC984 (CO meter)
SE981 (O₂ meter)

Main specifications (Type ZSQ)

Item	Description
Measurement component	CO, O ₂
Measuring method	CO: Non-dispersion infrared O ₂ : Zirconia
Measurement range	CO: 0~200/500, 0~200/1000, 0~500/1000, 0~500/2000ppm O ₂ : 0~25vol%
Repeatability	±0.5%FS
Zero drift	CO: ±2% FS/week. O ₂ : ±2% FS/month.
Span drift	±2% FS/week.
Linearity	±1%FS
Response speed	Within 90 seconds (90% response, from analyzer inlet)
Output signal	• 4 to 20mA DC, (linear) (CO instantaneous value, O ₂ instantaneous value, O ₂ correction CO instantaneous value, O ₂ correction CO moving average/1 and 4 hours) • Contact output (Peak count/alarm, auto calibration status, hardware error, etc.)
Functions	Auto calibration O ₂ correction calculating equation Average value calculating equation (moving average time 1 hour, 4 hours) CO peak count/alarm Recorder (option)
Ambient conditions	-5 to +40°C, 90% RH max.
Source voltage	100V AC, 50 or 60Hz
Dimensions	600(W)×1550(H)×650(D)mm for indoor use
Standard measurement gas conditions	Temperature: 800°C max. Dust: 100mg/Nm ³ max. Pressure: -1~+5, -3~+3, -5~+1kPa Components: SO ₂ 500 ppm max. NO _x 1000 ppm max. CO ₂ 15% max.

High speed concentration measurement for
NH₃ or HCl, H₂O, CO, CO₂, CH₄, O₂ in flue!

Laser gas analyzer <Type ZSS>

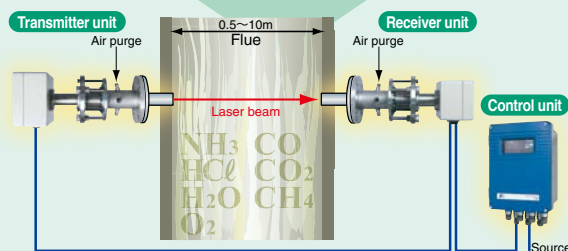

Features

- Excellent long term stability: ±1.0% FS/6 months (Zero drift)
- Ultrahigh response speed: 1 to 5 seconds
- Direct insertion requires practically no maintenance
- Hardly interfered with or affected by other gases
- Simultaneous measurement of 2 components (CO + O₂, CO + CO₂)
- Measurable at high temperatures and with high dust content
- Contributes to energy saving with a power consumption of about 80 VA

Main specifications (Type ZSS)

Item	Description
Measurement gas	HCℓ : 0 to 10...5000ppm CO ₂ : 0 to 2...50vol%
Measurement range	NH ₃ : 0 to 15...5000ppm CH ₄ : 0 to 100ppm...50vol%
	CO : 0 to 2...50vol% O ₂ : 0 to 4...100vol%
Note)	H ₂ O range is 50vol% fixed
	HCℓ+H ₂ O: 0 to 50...1000ppm(Note)
	NH ₃ +H ₂ O: 0 to 50...5000ppm(Note)
	CO+CO ₂ : 0 to 2.5...50vol%
	CO+O ₂ : 0 to 200ppm...50vol%(CO) 0 to 4...100 vol%(O ₂)
Measuring principle	Wavelength non-dispersion infrared (NDIR)
Installation method	Cross stack
Laser class	1M
Measurement optical path length (flue/stack width)	0.5~10m
Repeatability	±2.0% FS
Zero, span drift	±2.0% FS/6 months (±3.0% FS/6 months for NH ₃ range of 20ppm or less)
Response speed (= 90%)	1 to 5 seconds
Analog output	4-20mA DC, 0 to 1 V DC, 0 to 5V DC, 0 to 10V DC (as specified), 2 or 4 points
Analog input	4 to 20mA DC, 2 or 6 points
Communication function	USB or RS-485 (MODBUS)
Contact input (option)	3 points (Average value reset, remote hold, remote range changeover, instantaneous value/average value selection)
Contact output	5 points (beyond high/low limit range, power OFF, hardware error, calibration status/hold status)
Source voltage	100 to 240V AC, about 75VA
Ambient temperature, humidity	Receiver unit/Transmitter unit: -20 to 55°C, control unit: -5 to 45°C. 90% RH max.
Measurement gas temperature	1200°C max.
Measurement gas pressure	±10kPa
Dimensions (W×D×H)mm	Receiver unit (180×400×200mm) Transmitter unit (240×400×200mm) Control unit(240×135×320mm)
Mass	Receiver unit, Transmitter unit: About 10kg each. Control unit: About 8kg
Mounting	Control unit: On wall or pipe Receiver unit, Transmitter unit: By flange

⚠ Caution on Safety

* Before using products in this catalog, be sure to read their instruction manuals in advance.

FE Fuji Electric Co., Ltd.

International Sales Div.

Sales Group

Gate City Ohsaki, East Tower, 11-2, Osaki 1-chome,
Shinagawa-ku, Tokyo 141-0032, Japan

<http://www.fujielectric.com>

Phone: 81-3-5435-7280, 7281 Fax: 81-3-5435-7425

<http://www.fujielectric.com/products/instruments/>